

IZO MODEL 712 ELECTRIC

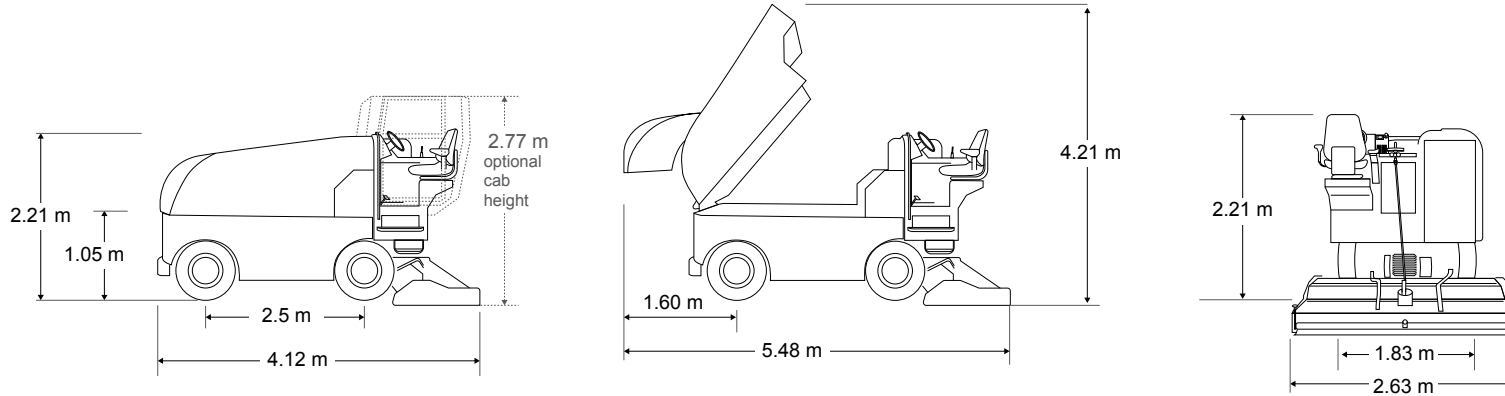

CAPACITIES

Snow Tank

Actual Volume	4.10 m ³	145 cu. ft.
Compacted	5.13 m ³	181 cu. ft.

Water

Ice Making	1650 L	436 gal.
Wash Water	400 L	106 gal.
Total	2050 L	542 gal.

Hydraulic Oil	22 L	5.8 gal.
----------------------	------	----------

POWERTRAIN

Four-Wheel Drive

Motors

Four Electric Wheel (traction) Motors	3.25 kW	4 HP
Electric Hydraulic Pump Motor	3 kW	4 HP
Two Electric Auger Motors	9 kW	12 HP
Total Energy Consumption of all Motors	34 kW	46 HP

Battery	625 Ah or 775 Ah (optional) 80 V	
----------------	----------------------------------	--

Axles

Front	7000 kg	15432 lb
Rear	7000 kg	15432 lb

Brakes	Full Hydrodynamic Braking with Front and Rear Drum Brakes
---------------	---

DIMENSIONS

Overall

	L	W	H	L	W	H
Snow Tank Down	4.12 m	2.63 m	2.21 m	162 in.	104 in.	87 in.
Snow Tank Up	5.48 m	2.63 m	4.21 m	216 in.	104 in.	166 in.

Shaving Blade

L	W	H	L	W	H
243.8 cm	12.7 cm	1.27 cm	96 in.	5 in.	0.5 in.

Clearance

Minimum Operator Height Clearance	2.31 m	91 in.
Snow Pit Clearance	105 cm	41.3 in.

Conveyor System

Horizontal Auger Diameter	25.4 cm	10 in.
Vertical Auger Diameter	25.4 cm	10 in.
Auger Length	243 cm	96 in.

Manueverability

Wheelbase	2.00 m	78.7 in.
Wheel Track	1.80 m	70.9 in.
Turning Radius at Conditioner	3.95 m	13 ft.

Weight

Empty	5330 kg	11751 lb
with Water	7380 kg	16270 lb



Enclosed Cab

The enclosed operator cab provides protection from the elements and a safe, comfortable working space. *optional equipment



Zamboni Connect™ System

Monitor consumption and optimize performance with predictive insight and resource management. *optional equipment



Blade Change Assistant

Allows operators to complete a safe and easy blade installation or removal without touching the exposed blade. *optional equipment

IZO MODEL
712
ELECTRIC

STANDARD FEATURES

- 2 Year Warranty
- Adjustable Steering Wheel
- Auto Ice Button for an Automated Start and Stop to All Resurfacing Processes
- Automated Wash Water Pump Start
- Automatic Snow Breaker
- Backup Alarm
- Battery Watering System
- Battery: Lead Acid with 5 Year Warranty
- Blade Change Ease of Access From Above
- Brushless AC Motors and Controls
- Charger Adjusted to Customer Specs and Microprocessor Controlled
- Chassis: Strong All Welded Steel Tubing
- Closed Wash Water System
- Dual Auger Startup
- Dynamic Stability and Traction Control
- Electric Water Valve Operation
- Electric Wheel Motors

- Emergency Stop Button
- Ergonomic Blade Adjustment Wheel
- Four-Wheel Drive
- Galvanized Steel Frame Rear Swing Axle
- Guide Wheel
- Hydraulic All Wheel Braking
- Hydraulic Oil Vacuum Pump
- Fiberglass Hydraulic Snow Tank Lid
- Ice Making Water Level Gauge
- Integrated Snow Tank Safety Stand
- Led Headlights And Tail Light
- Automatic / Manual Ice Making Water Control
- Non-Stick Snow Tank Liner
- On-Dash Digital System Performance Display
- On-Dash View of Wash Water Return Flow
- Parking Brake
- Power Cylindrical Board Brush

- Power Steering
- Premium Adjustable / Heated Seat
- Premium Spreader Towel
- Preset Speed Options For Ice Maintenance, Ice Hockey And Bandy
- Replaceable Conditioner Runners
- Replaceable Poly Conditioner Side Plates
- Safety Valve on Hydraulic Cylinders for Snow Tank and Conditioner
- Snow Tank Light and View Panel
- Spare Tire and Wheel
- Speed-Related Ice Making Water System
- Stainless Steel Wash and Ice Making Water Tank
- Stainless Steel Water Distribution Pipe
- Steering Wheel Spinner Knob
- Tire Wash System and Studded Tires
- Transparent Auger Viewing Panels
- Variable Auger Speed Based on Water Flow

- Wash Water Level Gauge
- Wash Water to IMW Transfer System
- Zamboni Connect Dashboard with Digital Reference Materials and Maintenance Log

OPTIONS

- Auger Washout System
- Automated Towel Bar Lift Raises Towel When Water Is Turned Off
- [Blade Change System](#)
- Cab
- Front Camera
- Machine-Mounted Edger
- Seatbelt
- Spray Boom
- Touch Up Paint Kit