

# MODEL 710

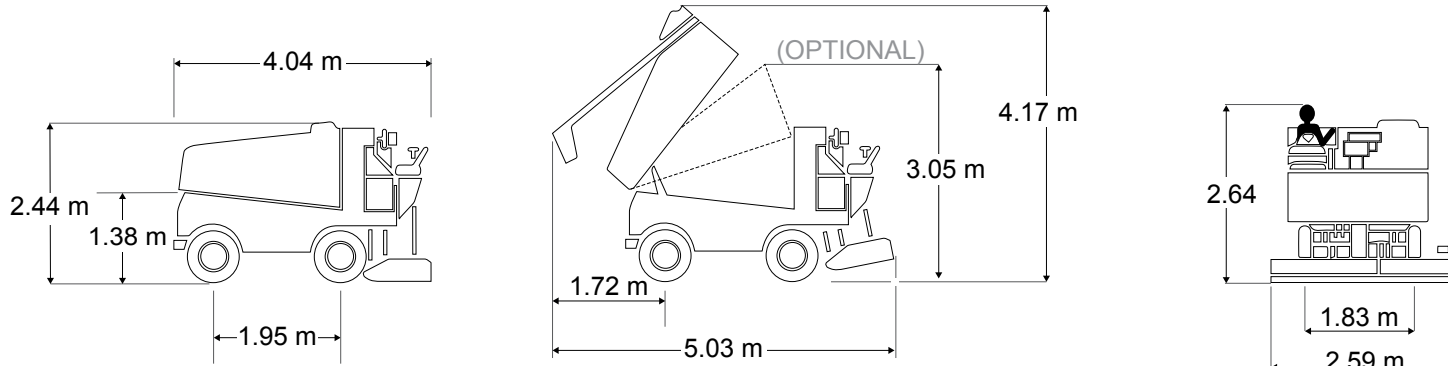

CAPACITIES		
<b>Snow Tank</b>		
Actual Volume	3.54 m <sup>3</sup>	125 cu. ft.
Compacted	4.53 m <sup>3</sup>	160 cu. ft.
Excess Water	662 L	175 gal.
<b>Water</b>		
Ice Making	1514 L	400 gal.
Wash Water	416 L	110 gal.
Total	1930 L	510 gal.
<b>Hydraulic Oil</b>	125 L	33 gal.
POWERTRAIN		
Four-Wheel Drive		
Engine	VM Motori® Industrial Diesel 3.0 L; Four Cylinder 79.2 kW / 106 HP at 2350 RPM EU Certified Engine	
Transmission	Continuously variable pump and motor are axial-piston type	
Hydraulics	Double pump powers the vertical and horizontal augers. Hydraulic down pressure for optimal resurfacing results.	
<b>Axles</b>	Rugged Dana Spicer® Model 70 Axles	
<b>Brakes</b>	Full Hydrodynamic Braking	

DIMENSIONS						
<b>Overall</b>	<b>L</b>	<b>W</b>	<b>H</b>	<b>L</b>	<b>W</b>	<b>H</b>
Snow Tank Down	4.04 m	2.59 m	2.44 m	159 in.	102 in.	96 in.
Snow Tank Up	5.03 m	2.59 m	4.17 m	198 in.	102 in.	164 in.
<b>Shaving Blade</b>	<b>L</b>	<b>W</b>	<b>H</b>	<b>L</b>	<b>W</b>	<b>H</b>
	243.8 cm	12.7 cm	1.27 cm	96 in.	5 in.	0.5 in.
<b>Clearance</b>						
Minimum Operator Height Clearance			264.2 cm	104 in.		
Snow Pit Clearance			1.38 m	54.5 in.		
<b>Conveyor System</b>						
Horizontal Auger Diameter			25.4 cm	10 in.		
Vertical Auger Diameter			25.4 cm	10 in.		
<b>Manueverability</b>						
Wheelbase			1.96 m	77 in.		
Wheel Track			1.83 m	72 in.		
Turning Radius at Conditioner			6.1 m	20 ft.		
<b>Weight</b>						
Empty			4273 kg	9420 lb		
with Water			6214 kg	13700 lb		

# MODEL 710



### Galvanized Conditioner

Durable galvanized steel provides a scratch-free finish with protection from rust.

\*optional equipment



### Zamboni Power Brush™

Wider brush path reaches higher on the dasher board kick plate for superior cleaning

power. \*optional equipment



### Automatic Snow Breaker

Eliminates the need for manual control of the snow breaker by the machine operator.

\*optional equipment

## STANDARD FEATURES

2 Year Warranty  
400 Micron Wash Water Deep Filter Bag  
Chassis: Strong All Welded Steel Tubing  
Chrome Wheels  
Conditioner Safety Guards  
Digital Training and Reference Materials  
Electronically Controlled Engine  
Engine: EU Certified  
Familiar Automobile-Style Foot Controls  
Four-Wheel Drive  
Fuel Tank: Large 100.7 L / 26.6 gal.  
Fuel: Diesel  
Full Hydrodynamic Braking  
Galvanized Steel Ice Making Water Tank  
Guide Wheel  
High Quality 9 and 10 Micron Filters  
High Speed Vertical Auger  
Hydraulic Oil Level Sight Gauge  
JIC Hydraulic Fittings

LED Headlights and Tail lights  
Load Sensing Engine Governor  
Multi-Function Display  
On-Dash Diagnostics  
Parking Brake  
Power Steering  
Replaceable Poly Conditioner Side Plates  
Rugged Dana Spicer® Axles  
Snow Tank Safety Stand  
Spare Tire and Wheel  
Stainless Steel Hardware  
Steering Wheel Spinner Knob  
Touch-Up Paint Kit  
Tungsten Carbide Studded Tires  
Turbo Charged Inner Cooled Engine  
Under Seat Storage  
Wide Spectrum of Premium Automotive Paint Colors

## OPTIONS

Automatic Snow Breaker  
Back Up Alarm  
Cab Enclosure  
Conditioner: Galvanized  
Electric Water Level Gauge  
Euro 6 EU Certified Engine  
Hydraulic Oil Cooler Kit  
IceCaps® Wheel Advertising System  
Low Fuel Light  
Snow Melting Kit  
Snow Tank Dump Height Restriction  
Snow Tank Light  
Tire Wash System  
Wash Water to Ice Making Water Transfer  
Zamboni Power Brush™ Board Brush System