

CAPACITIES

Snow Tank

Actual Volume	2.83 m ³	100 cu. ft
Compacted	3.54 m ³	125 cu. ft

Water

Ice Making	760 L	200 gal.
Wash Water	268 L	70 gal.
Total	1028 L	270 gal.

Hydraulic Oil

	95 L	25 gal.
--	------	---------

POWERTRAIN

Motors

Electric Hydraulic Pump Motor	10 kW	13 HP
Electric Traction Motor (2)	20 kW (per motor)	27 HP

Battery

Lithium-ion

Axles

Front	770 kg	1693 lb
Rear	3370 kg	7431 lb

DIMENSIONS

Overall

	L	W	H	L	W	H
Snow Tank Down	4.04 m	2.13 m	2.26 m	159 in.	84 in.	89 in.
Snow Tank Up	4.94 m	2.13 m	3.66 m	194 in.	84 in.	147 in.

Shaving Blade

	L	W	H	L	W	H
195.6 cm 77 in. Blade	195.6 cm	12.7 cm	1.27 cm	77 in.	5 in.	0.5 in.

Clearance

Minimum Operator Height Clearance		2.49 m	96 in.
Snow Pit Clearance		1.16 m	46 in.

Conveyor System

Horizontal Auger Diameter	25.4 cm	10 in.
Vertical Auger Diameter	25.4 cm	10 in.

Manueverability

Wheelbase	1.96 m	77 in.
Wheel Track	1.37 m	54 in.
Turning Radius at Conditioner	4.57 m	15 ft.

Weight

Empty	3210 kg	7080 lb
With Water	4140 kg	9120 lb

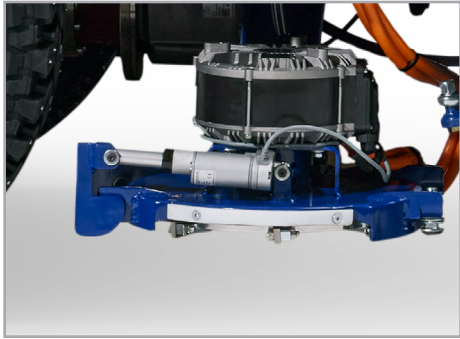

Euro Edger +

The onboard edger saves time, performing the edging process during a routine resurfacing.



Joystick Controller +

The joystick controller provides additional familiarity and ease of operation for routine resurfacing processes.



12" Digital Touch Display ✓

The larger digital display increases visibility and allows touch navigation to access information on the go.



✓ STANDARD

- 2 Year Warranty
- 4WD
- Advanced Water System
- Auto Ice: Automated Resurfacing
- Battery: Lithium-ion
- Battery: Slide-out Battery Tray
- Blade Adjustment: Electric
- Board Brush: Conical
- Body Panels: Removable
- Charger: Onboard EV Compatible Charger
- Charging Port: Left Side
- Chassis: Welded Steel
- Corrosion-resistant Poly IMW Tank
- Display: 12" Digital Touch Screen
- Emergency Stop
- Guide Wheel
- Headlights: LED
- Hydraulic Oil Level Sight Gauge
- Hydraulic Oil Temperature Sensor
- Ice Making Water Level Gauge

- Ice Making Water Pipe: Stainless Steel
- Motors: Brushless AC Motors
- Motors: Dual Electric Traction Motors
- On-Dash Diagnostics
- Parking Brake
- Power Steering
- Safety: Dual Snow Tank Safety Stands
- Service Manual: Online
- Snow Breaker: Automatic
- Snow Tank Light
- Stainless Steel Hardware
- Tires: Tungsten Carbide Studded
- Towel: Durable Polyester Felt
- Wheels: Aluminum Alloy
- Wide Spectrum of Premium Paint Colors

+ OPTIONS

- Auger Washout System
- Board Brush: Cylindrical Power Brush™
- Charging Port: Right Side
- Chassis: Galvanized Steel
- Conditioner: Galvanized Steel
- Conditioner: Quick Blade Change System
- Euro Edger: On Board Edger
- FastICE® Advanced Ice Making System
- Ice Making Water Temperature Sensor
- IceCaps® Wheel Advertising System
- Joystick Controller
- Level-Ice® Laser Leveling System
- Light: Body Flashing Light
- Lighting: Body Accent Lights
- Multiview Camera System
- Proximity Sensor System
- Safety: Backup Alarm
- Seat Belt
- Seat: Heated Comfort Seat
- Snow Tank Dump Height Restriction

- Snow Tank Window Lift: Electric
- Snow Transfer Light
- Tire Wash System
- Towel Lift: Electric
- Turn Signal
- Wash Water: 400 Micron Deep Filter Bag
- Wash Water System With Poly Tank
- Wash Water Temperature Sensor
- Water Transfer Valve: Electronic
- Zamboni Connect™ System