

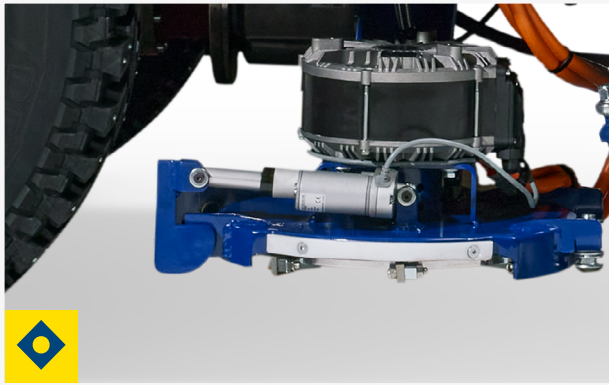





BUILT FOR THE ICE. DESIGNED FOR THE ICE MAKER.

Optimizing familiar technologies and automating processes, the ZX5 allows for consistency between operators and savings of time and resources.





-  Optional Euro Edger saves time, performing edging during a regular resurfacing
-  Optional joystick for ease of operation and automated blade/water control for consistency between operators
-  Capacities match or exceed those of the Zamboni 500 Series models
-  Quick blade change system with left and right side access for a faster, safer process



This brochure has been prepared only as a general guide for the customer. Every effort has been made to assure that the information presented is correct. Some features described or shown may be optional at extra cost. Prices, colors, materials, specifications and models are subject to change. For current product information, please contact the Zamboni Company.



STANDARD EV PLUG CHARGING

Facilities can procure the charger of their choice or use existing Level 1 or Level 2 EV charge stations to replenish the lithium-ion batteries between resurfacings.



MISSION CONTROL

Electronic controls at your fingertips. Digital dash display features state of charge, water consumption/temperature, ground speed, blade adjustment, enhanced diagnostics, and optional systems such as FastICE® and Level-Ice®. All machine functions are coordinated, streamlining its operation, and maximizing efficiencies.



ENERGY EFFICIENCY

Resurfacing parameters can be optimized to conserve energy and water. State-of-the-art hydraulics and a reimagined power train deliver a more efficient design that reduces the amount of energy used during a resurfacing.



LOW MAINTENANCE

Lithium-ion batteries are sealed and maintenance-free. Corrosion-free removable body panels and a slide-out battery tray allow ease of access. Scheduled maintenance alerts are programmed and displayed via the on-dash touchscreen.



GLOBAL SERVICE AND SUPPORT

Zamboni Customer Service and a network of Zamboni Authorized Distributors provide exceptional and accessible service and support worldwide.

ZAMBONI
zamboni.com

ZAMBONI and the configuration of the Zamboni® ice resurfacing machine are registered trademarks of Frank J. Zamboni & Co., Inc.
© Zamboni 2023